

6 3X M5X0.8 - 6H ∇ 9.0

6 4X M4X0.7 - 6H ∇ 6.0 MIN

- 1 MOTOR LEADS EXIT FROM SHOWN. BARE LEADS TYPICAL.
- 2 FAN LEADS EXIT FROM SHOWN. BARE LEADS TYPICAL.
- 3 PROPER OPERATING DIRECTION WHEN VIEWED FROM RESPECTIVE ORIENTATION.
- 4 WORKING FLUID INLET PORT: 1/4 NPT
- 5 WORKING FLUID OUTLET PORT: 1/4 NPT
- 6 MOUNTING PROVISIONS.
- 7 FAN AIRFLOW DIRECTION.
- 8 MAXIMUM ALLOWABLE INPUT CURRENT TO THE CONTROLLER AT NOMINAL VOLTAGE.

COMPRESSOR SPECIFICATIONS	
VOLUME RATIO	3.06
SUCTION VOLUME	15.24 cc
MAX PRESSURE	3.5 Barg 50 Psig
MAX FLOW	50 LPM 1.77 CFM
MASS	2.26 Kg 5 Lb
RATED SPEED	3500 RPM
MOTOR SPECIFICATIONS	
NOMINAL VOLTAGE	24 V
CURRENT LIMIT ∇ 8	13 A
# OF POLES	8
FAN SPECIFICATIONS	
VOLTAGE RATING	24 VDC
CURRENT RATING	0.12 A
POWER	2.88 W

DEFAULT TOLERANCES:
 X. \pm 2.0
 .X \pm 1.0
 .XX \pm 0.50
 .XXX \pm 0.100
 ANGULAR \pm 3.0°
 INTERPRET DRAWING PER ASME Y14.5-2009

CONFIDENTIAL. THIS DOCUMENT AND THE DATA DISCLOSED HEREIN OR HERewith IS NOT TO BE REPRODUCED, USED, OR DISCLOSED IN WHOLE OR IN PART TO ANYONE WITHOUT THE PERMISSION OF AIR SQUARED, INC.
 DIMENSIONS ARE IN MM
 SHEET 1 OF 2 SCALE: 1:1.5

Air squared

DESCRIPTION:
SALES LAYOUT

SIZE B	PART NO. P09H017A-D01	REV. 0
------------------	---------------------------------	------------------

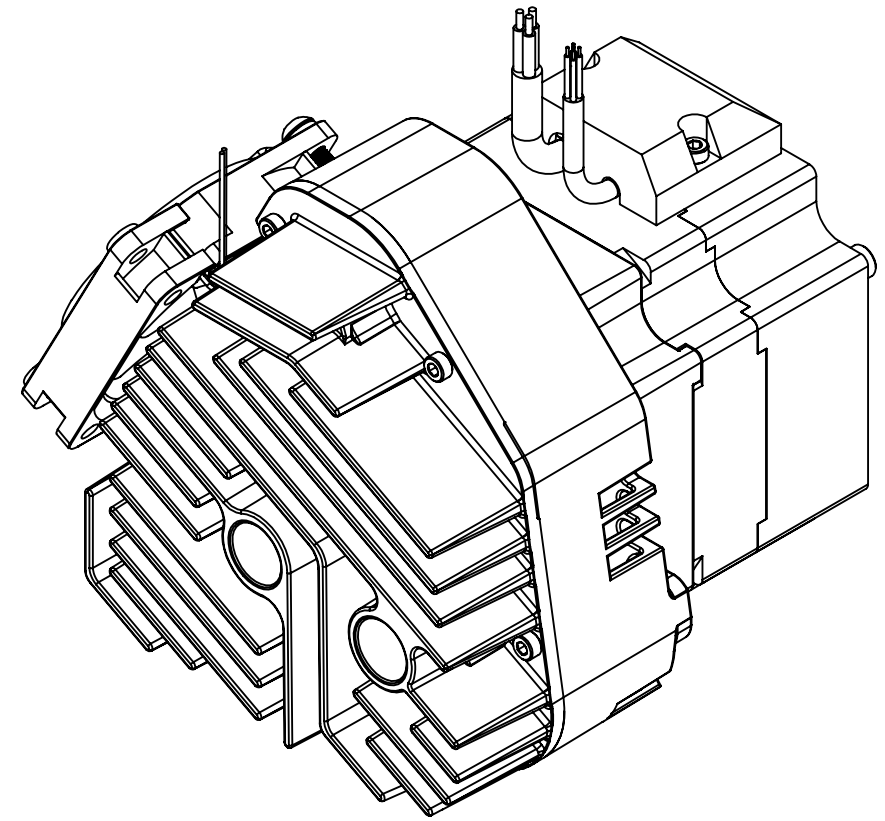
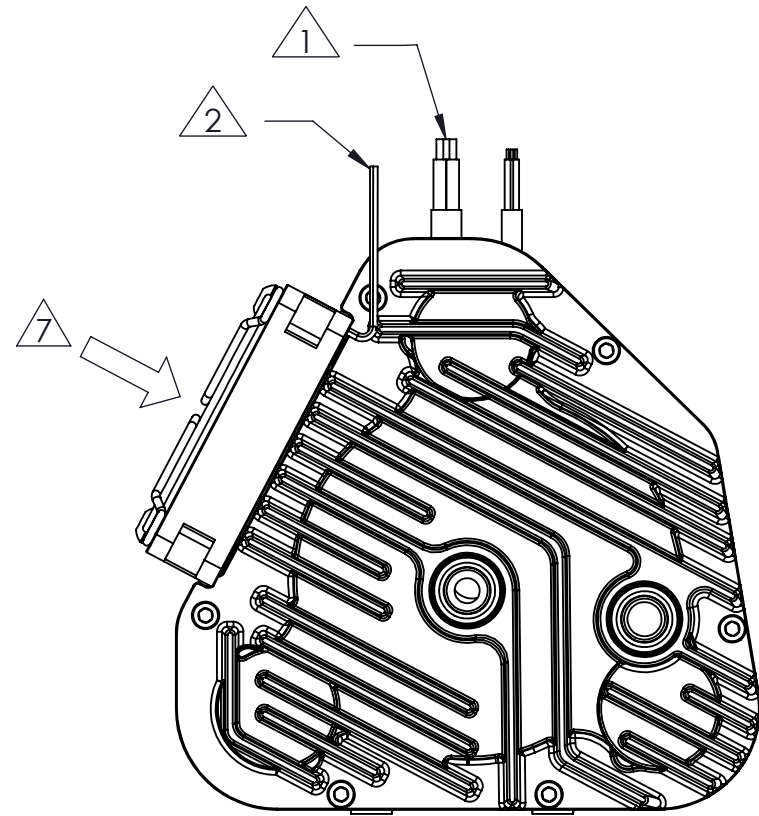

MOTOR WIRING - REFERENCING WIRING
DIAGRAM P09H017A-D01-C1

MOTOR POWER		
WIRE COLOR	SIGNAL	WIRE SIZE
YELLOW	PHASE B	2 MM ²
GREEN	PHASE C	2 MM ²
BLUE	PHASE A	2 MM ²
HALL SENSORS		
WIRE COLOR	SIGNAL	WIRE SIZE
YELLOW	S1	0.2 MM ²
GREEN	S2	0.2 MM ²
BLUE	S3	0.2 MM ²
RED	VCC	0.2 MM ²
BLACK	GND	0.2 MM ²
FAN POWER		
WIRE COLOR	SIGNAL	WIRE SIZE
RED	+	28 AWG
BLACK	-	28 AWG

DEFAULT TOLERANCES: X. ± 2.0 .X ± 1.0 .XX ± 0.50 .XXX ± 0.100 ANGULAR ± 3.0°	CONFIDENTIAL. THIS DOCUMENT AND THE DATA DISCLOSED HEREIN OR HERewith IS NOT TO BE REPRODUCED, USED, OR DISCLOSED IN WHOLE OR IN PART TO ANYONE WITHOUT THE PERMISSION OF AIR SQUARED, INC.			
		DESCRIPTION: SALES LAYOUT		
INTERPRET DRAWING PER ASME Y14.5-2009	DIMENSIONS ARE IN MM SHEET 2 OF 2 SCALE: 1:1.5	SIZE B	PART NO. P09H017A-D01	REV. 0