

COMPRESSOR SPECIFICATIONS		
VOLUME RATIO	1.39	
SUCTION VOLUME	463 cc	
MAX PRESSURE	1.2 Bar _g	17.4 PSI _g
MAX FLOW	950 LPM	33.5 CFM
MASS	27 kg	59.5 Lb
RATED SPEED	2000 RPM	
MOTOR SPECIFICATIONS		
NOMINAL VOLTAGE	48 VDC	
CURRENT LIMIT	50 A	8
# OF POLES	8	
FAN SPECIFICATIONS		
VOLTAGE RATING	48 VDC	
CURRENT RATING	0.2 A	
POWER	9.6 W	

- 1 MOTOR LEADS EXIT FROM SHOWN. BARE LEADS TYPICAL
- 2 FAN LEADS EXIT FROM SHOWN. BARE LEADS TYPICAL
- 3 PROPER OPERATING DIRECTION WHEN VIEWED FROM RESPECTIVE ORIENTATION
- 4 WORKING FLUID INLET PORT: 1.5" ELBOW HOSE CONNECTION
- 5 WORKING FLUID OUTLET PORT: 1.5" ELBOW HOSE CONNECTION
- 6 MOUNTING PROVISIONS
- 7 FAN AIRFLOW DIRECTION
- 8 MAXIMUM ALLOWABLE INPUT CURRENT TO THE CONTROLLER AT NOMINAL VOLTAGE

DEFAULT TOLERANCES:
 X. ± 2.0
 .X ± 1.0
 .XX ± 0.50
 .XXX ± 0.100
 ANGULAR ± 3.0°

INTERPRET DRAWING PER
 ASME Y14.5-2009

CONFIDENTIAL.
 THIS DOCUMENT AND
 THE DATA DISCLOSED
 HEREIN OR HEREWITH IS
 NOT TO BE
 REPRODUCED, USED, OR
 DISCLOSED IN WHOLE
 OR IN PART TO ANYONE
 WITHOUT THE
 PERMISSION OF AIR
 SQUARED, INC.

DIMENSIONS ARE IN MM

Air squared

DESCRIPTION:
SALES LAYOUT

SIZE B	PART NO. P27H069A-B01	REV. 5
------------------	---------------------------------	------------------

SHEET 1 OF 2 SCALE: 1:5

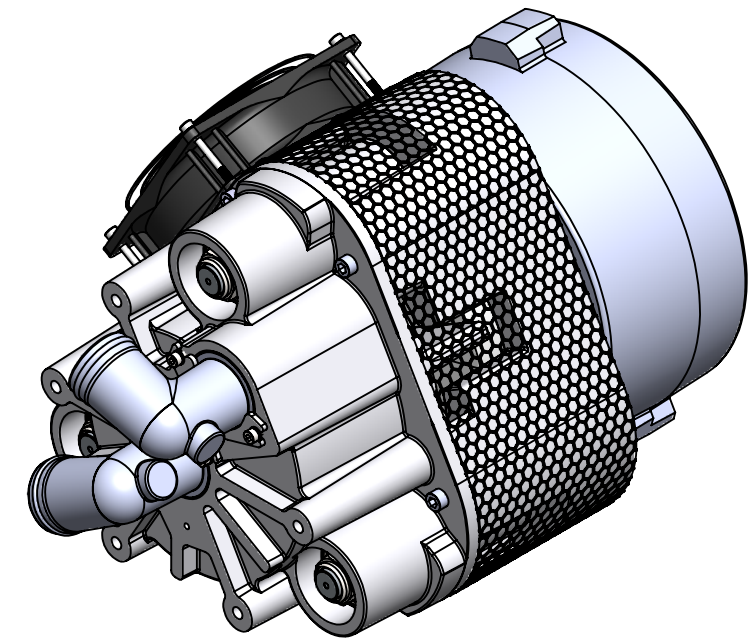
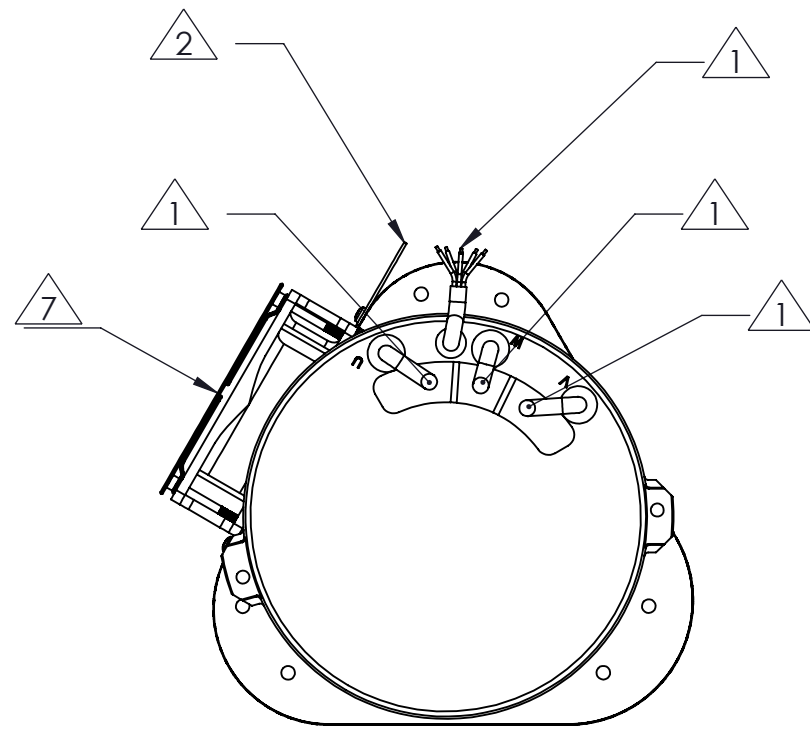
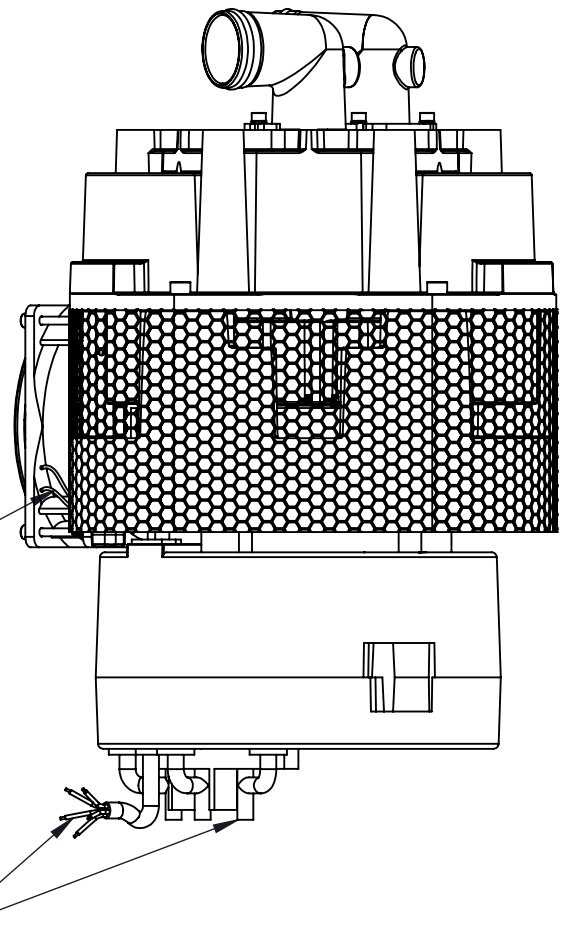

MOTOR WIRING - REFERENCE 940044-ASSY

MOTOR POWER	
WIRE SIGNAL	SIGNAL
U	∅ A
V	∅ C
W	∅ B
HALL SENSORS	
WIRE COLOR	SIGNAL
WHITE	S1
GREEN	S2
BLUE	S3
RED	VCC
BLACK	GND

FAN POWER	
RED	+
BLACK	-

DEFAULT TOLERANCES: X. ± 2.0 .X ± 1.0 .XX ± 0.50 .XXX ± 0.100 ANGULAR ± 3.0°	CONFIDENTIAL. THIS DOCUMENT AND THE DATA DISCLOSED HEREIN OR HEREWITH IS NOT TO BE REPRODUCED, USED, OR DISCLOSED IN WHOLE OR IN PART TO ANYONE WITHOUT THE PERMISSION OF AIR SQUARED, INC.			
		DESCRIPTION: SALES LAYOUT		
INTERPRET DRAWING PER ASME Y14.5-2009	DIMENSIONS ARE IN MM SHEET 2 OF 2 SCALE: 1:5	SIZE B	PART NO. P27H069A-B01	REV. 5